

# MSD Servo Drive

Specification



**4 ... 20 mA Inputs  
on Control Card**

Description of  
Basic Functionality

MSD 4...20 mA Inputs on control card

Id no.: CB57187-001, Rev. 1.3

Date: 10/2022

## MSD 4...20 mA Inputs on Control Card

The standard MSD Servo Drives are equipped with two analog input interfaces of type +/-10 V. With this interface no wire break detection is possible. Also in some applications it is necessary to read in signals from sensors with a 4...20 mA interface.

Due to that, a variant of the MSD Servo Drive control card has been developed which allows to read in analog signals of type 4...20 mA. Also the firmware of the servo drives has been adjusted so that via parameters it is possible to if either a standard control card with +/-10 V or the variant with 4...20 mA inputs are used

These drives can be used for different functionalities and applications. Typical applications for this function are:

- Reading in sensors with 4...20 mA for functions being programmed in the programming interface or the MSD PLC
- Reading in sensor for closing servo loops with the internal process controller
- Reading demand signals from PLC's with a 4...20 mA interface to the standard MSD Servo Loops.

## Technical alterations reserved

The contents of our documentation have been compiled with greatest care and in compliance with our present status of information.

Nevertheless we would like to point that this document cannot always be updated parallel to the technical further development of our products.

Information and specifications may be changed at any time. For information on the latest version please refer to [drives-support@moog.com](mailto:drives-support@moog.com).

# Table of Contents

- 1 Availability ..... 4
- 2 Interface description..... 4
  - 2.1 Technical data and Pin assignment .....4
  - 2.2 Additional information .....5
  - 2.3 Cascading of analog inputs.....5
- 3 Configuration ..... 6
  - 3.1 Analog channel ISA0x .....6
  - 3.2 Weighting.....7
  - 3.3 Wire break detection .....8

This document does not replace the MSD Servo Drive Operation Manual. Please be sure to observe the information contained in the “For your safety”, “Intended use” and “Responsibility” sections of the Operation Manual (ID no.: CA65642-001). For information on installation, setup and commissioning, and details of the warranted technical characteristics of the MSD Servo Drive series, refer to the additional documentation (Operation Manual, User Manual, etc.).

This document provides information about how to connect and how to set-up the 4...20 mA function on the control card if a mating servo drive is used.

## Referenced Documents

Title	Document No. (English)	Document No. (German)
MSD Servo Drive Device Help	CB40859-001	CB40859-002
Moog DRIVEADMINISTRATOR 5 Installation Manual	CA50726-001	CA50726-002
MSD Servo Drive AC-AC Servo Drive Operation Manual Single-Axis System	CA65642-001	CA65642-002
MSD Servo Drive DC-AC Servo Drive Operation Manual Multi-Axis System	CA97554-001	CA97554-002

Audience



# 1 Availability

This function is available for the following MSD Servo Drive devices:

Series	Model	Hardware version	Firmware Version
MSD Servo Drive Single-Axis System	G392-xxx-xxxx1xx G395-xxx-xxxx1xx	From Rev. C	From 123.xx-xx
MSD Servo Drive Multi-Axis System	G393-xxx-xxxx1xx G397-xxx-xxxx1xx	From Rev. C	From 123.xx-xx

# 2 Interface description

## 2.1 Technical data and Pin assignment

The following table describes the technical data of the analog 4...20 mA inputs on the control card.

Desc.	Terminal	Specification	Electrical isolation
Analog inputs			<b>X4</b>
ISA0+ ISA0- ISA1+ ISA1-	X4/3 X4/4 X4/5 X4/6	<ul style="list-style-type: none"> <li>• <math>I_{in} : 0 \dots 20 \text{ mA}</math></li> <li>• Resolution: 11-bit</li> <li>• Terminal sampling cycle in "IP mode" = 125 <math>\mu\text{s}</math>, otherwise 1 ms</li> <li>• Tolerance: +/-1% of the measuring range end value over the entire temperature range</li> <li>• Input Resistance: 215 <math>\Omega</math></li> </ul>	no

1) The border shows the pins on connector X4 for the analog 0 ... 20 mA inputs.

## 2.2 Additional information

As this function is a modification of the standard MSD Servo Drive analog inputs, also the same pins of connector X4 are used. The naming stays the same as well as for the standard inputs as in the firmware a selector has been added to define if the inputs are either current or voltage inputs.

The maximum common mode voltage with respect to GND for each input shall not be bigger than 30 V. The maximum voltage between ISAx+ and ISAx- due to normal operation must not be bigger than 10 V.

The leakage currents of this input circuit at the MSD Servo Drives are smaller than 50  $\mu$ A.

A short circuit protection is currently not implemented in this modification.

## 2.3 Cascading of analog inputs

Analog inputs of 4...20 mA are allowing the possibility to cascade several inputs in a row. With this it is possible to read the signals from one sensor into several devices at the same time. Also the analog 4...20 mA inputs at the MSD Servo Drive on the control card are allowing this.

This correct operation depends on the leakage currents of the used analog input circuits. The analog inputs on the MSD Servo Drive control card are as follows:  $I_{in}$  –  $I_{out} < 50 \mu$ A. For a correct operation it is recommended to place the analog inputs of the MSD Servo Drives at the end of the connection cascade.

The following principle circuit figure shows how the cascading has to be done for correct operation.

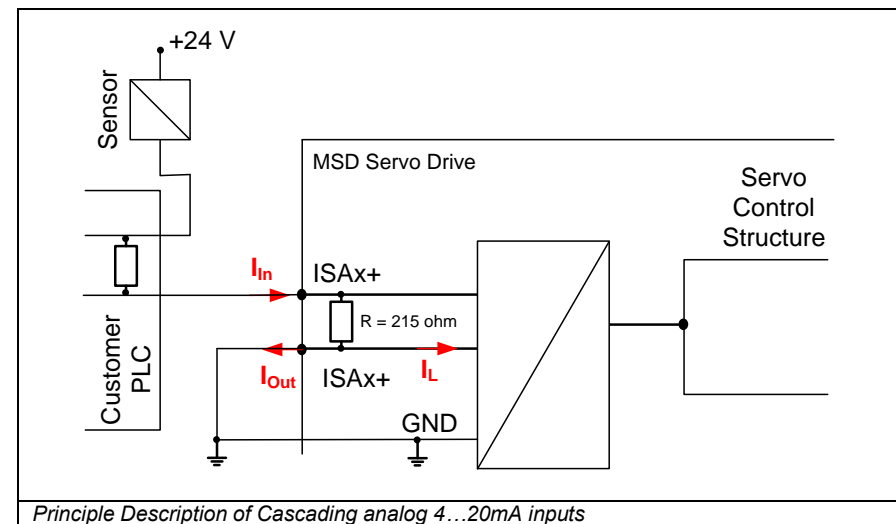

### 3 Configuration

#### 3.1 Analog channel ISA0x

For this function the selection for the two channels have been increased to fulfil the extra needs of the 4...20 mA inputs. To be able to specify reference set points for the control via the two analog inputs ISA0 and ISA1 or just process them for further use in the MSD PLC or the programming interface, the following function selectors have to be set accordingly.

Setting of analog input ISA0/1:

**P0109, P0110** must each be set to REV(-2) for analog command to the internal servo loops or to (-1) for just processing them for use in the MSD PLC or a customized firmware. The functions usable in analog mode are indicated by a (-) mark.

Parameter	Parameter name / Settings	Designation in MDA5	Function
<b>P0109</b> <b>P0110</b>	MPRO_INPUT_FS_ISA0/1	Function of analog input ISA0/1	Function of the analog input
	REFV(-2)	Analog command	The analog reference can be passed on to the control
	(-1)	Processing analog input	The analog input is just processed without being transferred to the control – parameters are available for further use in MSD PLC or a customized Firmware.
<b>P0165</b>	MPRO_REF_SEL	Motion profile selection	Reference selector
	ANAO/1	Via analog channel ISA00/01	Selection of the analog reference source – needs only be set to this value in case of setting REFV(-2). Otherwise this parameter needs to be set to the mating value of the command source (e.g. fieldbus)

Depending on the parameterized control mode (**P 0300 CON\_CfgCon**), a speed or a torque can be set as the reference by setting above parameters accordingly. Otherwise the inputs can be set also in that way so that the inputs are only processed and then are then available for the MSD PLC, a customized firmware or also just transmitted to a superimposed PLC via fieldbus.

#### Structure

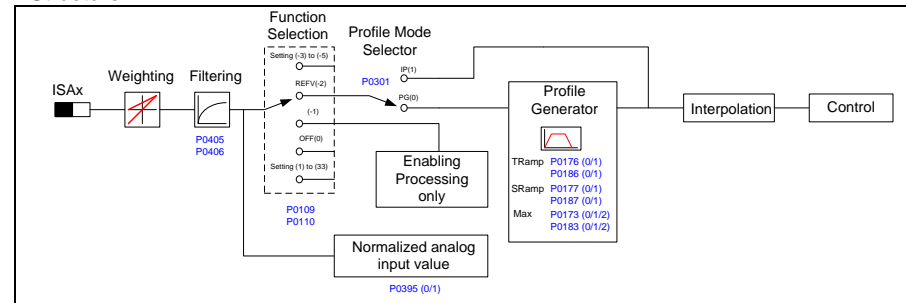

Processing of 4...20 mA analog inputs on Control Card (analog channel ISA00 and ISA01)

Parameters for reference processing are available for all control modes (torque, speed and position control). The scaling, weighting, an offset and a threshold (dead travel) are programmable. The parameters are described in the following sections. The reference can also be filtered via parameters **P0405 CON\_ANA\_Filt0** and **P 0406 CON\_ANA\_Filt1**.



Note: For additional information on profile generator and interpolated modes please refer to the MSD Servo Drive Device Help.

## 3.2 Weighting

It is possible to change the weighting of the analog inputs. With the six parameters **P0396** (0/1), **P0397** (0/1) and **P0398** (0/1) the input weighting can be set. The Sub-indexes 0 are valid for analog input ISA00 while the Sub-indexes 1 are valid for analog input ISA01

Changes require a device restart

Reasons for the need of changing the weighting can be:

- Change the weighting to meet the limiting range: 4...20 mA -> 0...100% (e.g. Torque limiting, sensor scaling,...)
- Change the weighting to meet the speed / position loop command range: 4...20 mA -> +/- 100% (e.g. reference scaling)

The following illustration shows how the weighting function works.

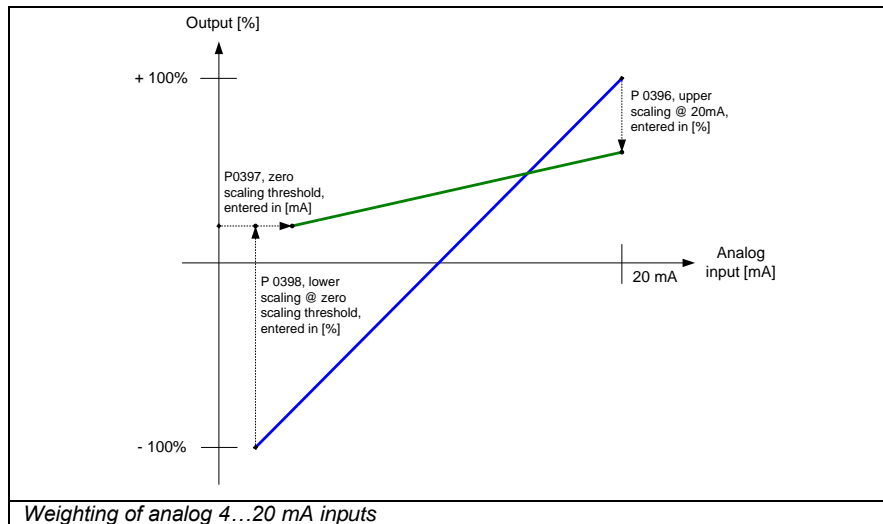

Weighting Example:

The standard measuring range is 0...20 mA, which corresponds to 0...100 %. In order to get 0...100 % at 4...20 mA, 4 mA is entered as the new 0 % value in **parameter 0397**, the new measuring range now begins at 4 mA. Values below 4 mA are then no longer evaluated. To activate the new setting, a device restart is required.

Signal flow for use in the hydraulic package

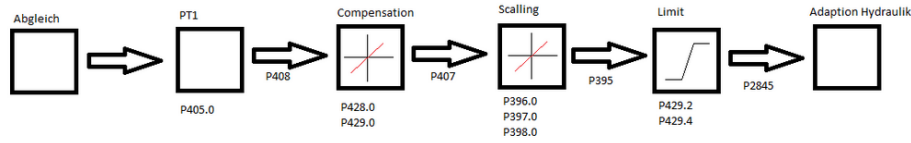

The following table gives a description about the weighting parameters

Parameter	Parameter name / Settings	Designation in MDA5	Function
<b>P0395</b>	CON_ANA_Isaf_Scaled	Scaled, compensated, filtered, normalized value	Transfer value for hydraulic package
0	ISA00		Value for input ISA00
1	ISA01		Value for input ISA01
<b>P0396</b>	CON_ANA_Scale_ThUpper	Upper scaling limits	Defining the output value in [%] @ 20 mA
0	ISA00		Value for input ISA00
1	ISA01		Value for input ISA01
<b>P0397</b>	CON_ANA_Scale_ThZero	Zero scaling thresholds	Defining the input value of the lower zero threshold in [mA]
0	ISA00		Value for input ISA00
1	ISA01		Value for input ISA01
<b>P0398</b>	CON_ANA_Scale_ThLower	Lower scaling limits	Defining the output value in [%] @ zero threshold
0	ISA00		Value for input ISA00
1	ISA01		Value for input ISA01

Parameter	Parameter name / Settings	Designation in MDA5	Function
<b>P0405</b>	CON_ANA_Filt0	Analog Input ISA00	Filter time constant for ISA
<b>P0407</b>	CON_ANA_Isaf	Compensated, filtered, normalized value	Analog value before scaling
0	ISA00		Value for input ISA00
1	ISA01		Value for input ISA01
<b>P0408</b>	CON_ANA_Isaf_Norm	Filtered, normalized value	Analog input Raw value
0	ISA00		Value for input ISA00
1	ISA01		Value for input ISA01
<b>P0428</b>	CON_ANA_Offset	Analog inputs: offset	Offset for analog inputs in [mA]
0	ISA00		Value for input ISA00
1	ISA01		Value for input ISA01
<b>P0429</b>	CON_ANA_Gain	Analog inputs: gain scaling	Scaling for analog inputs
0	ISA00_Gain		Gain scaling for ISA00
2	ISA00_limMin		Min value for ISA00
4	ISA00_limMax		Max value for ISA00
<b>P2845</b>	pAct	Hydraulic actual pressure	Pressure value for Hydraulic



### 3.3 Wire break detection

For the 4...20 mA analog inputs, a wire break detection has been implemented. Via a parameter it is possible to define the signal level below which the servo drive may go into an error mode and performs an error reaction. There are separate parameters available – one for each analog input (parameter **P0395 (0/1)**).

Parameter	Parameter name / Settings	Designation in MDA5	Function
<b>P0399</b>	CON_ANA_Wire Brk_Th	Wire break threshold	Defining the detection level for the wire break condition
0	ANA0		Value for input ISA00
1	ANA1		Value for input ISA01

The failure reaction for this error detection is set via parameter **P0030**, Subindex 52. The following table gives an overview about the available failure reactions which can be set for the wire break error detection on an analog input.

Parameter	Parameter name / Settings	Designation in MDA5	Function
<b>P0030, Sub 52</b>	Error Reactions	Programmable reaction in case of an failure	Error Reaction
(0)	Ignore	Ignore error	The error is ignored
(1)	Specific1	Notify error, reaction is forced by internal PLC function block	A specific error reaction can be programmed via PLC.
(2)	Specific2	Notify error, reaction is forced by external control unit	Error reaction external
(3)	FaultReactionOptionCode	Notify error, reaction as given by fault reaction option code	The error reaction is based on the value set in object 605Eh "Fault reaction option code"
(4)	ServoStop	Notify error, execute quick stop and wait for restart of control	Quick stop, waiting for restart of control
(5)	ServoStopAndLock	Notify error, execute quick	Quick stop, block power stage, secure against

		stop and wait for restart of control	switching on
(6)	ServoHalt	Notify error, disable power stage	Block power stage

Parameter	Parameter name / Settings	Designation in MDA5	Function
<b>P0030, Sub 52</b>	Error Reactions	Programmable reaction in case of an failure	Error Reaction
(7)	ServoHaltAndLock	Notify error, block power stage, protect against restart	Block power stage, block enable
(8)	WaitERSAndReset	Notify error, block power stage and reset only via switching off/on control voltage (24 V)	Block power stage, reset only by switching the 24 V control voltage off and back on

## TAKE A CLOSER LOOK.

Moog solutions are only a click away. Visit our worldwide Web site for more information and the Moog facility nearest you.

# MOOG

Moog GmbH  
Hanns-Klemm-Straße 28  
D-71034 Böblingen  
Telefon +49 7031 622 0  
Telefax +49 7031 622 100

[www.moog.com/industrial](http://www.moog.com/industrial)  
[drives-support@moog.com](mailto:drives-support@moog.com)

Moog is a registered trademark of Moog, Inc. and its subsidiaries.  
All quoted trademarks are property of Moog, Inc. and its subsidiaries.  
All rights reserved.  
© 2022 Moog GmbH

### **Technical alterations reserved.**

The contents of our documentation have been compiled with greatest care and in compliance with our present status of information.

Nevertheless we would like to point that this document cannot always be updated parallel to the technical further development of our products.

Information and specifications may be changed at any time. For information on the latest version please refer to [drives-support@moog.com](mailto:drives-support@moog.com).

Id no.: CB57187-001 Rev. 1.3, 01/2022